

PAPER • OPEN ACCESS

## SLAM-GDM Implementation on Robot Operating System for Gas Source Localization

To cite this article: K W Soo *et al* 2019 *IOP Conf. Ser.: Mater. Sci. Eng.* **705** 012018

View the [article online](#) for updates and enhancements.

You may also like

- [Design and Implementation of Ultrasonic Gas Leakage Locating System](#)  
Yongle Cao, Dongjian Wang, Ming Zhu *et al.*
- [Timelines for mitigating the methane impacts of using natural gas for carbon dioxide abatement](#)  
Magdalena M Klemun and Jessika E Trancik
- [Research on Calibration device of gas leakage alarm system and uncertainty analysis](#)  
Xing Liu, Maoyuan Qin, Zhongzhi Yang *et al.*



The Electrochemical Society  
Advancing solid state & electrochemical science & technology

**247th ECS Meeting**  
Montréal, Canada  
May 18-22, 2025  
*Palais des Congrès de Montréal*

**Abstracts due December 6th**

**Showcase your science!**

**ECS UNITED**

# SLAM-GDM Implementation on Robot Operating System for Gas Source Localization

K W Soo<sup>1</sup>, K Kamarudin<sup>1,2</sup>, V H Bennetts<sup>3</sup>, R Visvanathan<sup>2</sup>, A S Ali Yeon<sup>2</sup>, S M Mamduh<sup>2</sup>, A Zakaria<sup>1,2</sup>

<sup>1</sup>School of Mechatronics Engineering, Universiti Malaysia Perlis (UniMAP), Arau, Malaysia,

<sup>2</sup>Centre of Excellence for Advanced Sensor Technology (CEASTech), Universiti Malaysia Perlis, Arau, Malaysia

<sup>3</sup>Applied Autonomous Sensor systems, Orebro University, Orebro, Sweden

kamarulzaman@unimap.edu.my

**Abstract.** Gas Distribution Mapping (GDM) can be defined as visualization for the spatial distribution of gas concentration in an unknown indoor environment. Recently, incidents of gas leakage have increased gradually worldwide. This will significantly increase the casualty rate at the workplace. This paper focusses on the implementation of Kernel DM based SLAM-GDM on Robot Operating System (ROS), a novel approach that will be useful in the effort of localizing the gas source during gas leakage inspection. This approach has been conducted successfully by using ROS-architecture implemented system, tested in simulation and on a mobile robot. The result shows that this implementation achieved average accuracy of 0.71m and 0.32m and therefore deemed suitable for gas source location prediction.

## 1. Introduction

Gas related research has been conducted for 25 years. To the authors' knowledge, at least four gas leakage incidents have occurred worldwide in the month of April 2019 [1]–[4]. These have indicated the importance of the gas source localizing technique in this industry. With the advance of technology and mobile robot, gas distribution modelling by integrating gas sensing capability on the mobile robot is believed to provide promising result.

Mobile robot is emerging as a powerful and revolutionary technology for different industries. It is now not only employed in production line [5] but also implemented for education [6], hospitality [7], medical [8] and even household [9]. The adaptation of mobile robot in the industries has improved their performances in different aspect [10]. This is due to mobile robot exhibits certain characteristics better than human to accomplish certain tasks such as environmental monitoring. For an example, a mobile robot can be exposed to dangerous environments. This enables human to access, analyze and carry out the counter measurement for the condition of a lethal environment with lower casualties. Besides that, with the implementation of a statistical approach algorithm such as Kernel DM on the mobile robot, a gas distribution mapping of the environment can be obtained. Its 2D SLAM-GDM representation will significantly assist the localization of the gas source which is very important especially in Urban Search and Rescue (USAR) operation.



This paper proposes an implementation of GDM in ROS environment using gas distribution modelling algorithm, Kernel DM. The algorithm is then integrated with an open source non-odometry dependent SLAM, Hector SLAM for real-time SLAM-GDM solution. The integration of SLAM and GDM is implemented based on the approach proposed by [11]. The expected result would be a representation of gas distribution modelling of mobile robot's environment, capable to assist human to predict and identify gas source location.

## 2. Related Work

### 2.1. Simultaneous Localization and Mapping (SLAM)

In a mobile robot related project, it is very important for the robot to be able to localize itself in an unknown environment while building a map of it. Building a map is also known as mapping. It is a task to visualize the geometry features of an unknown environment by using input from sensors such as camera [12], [13], ultrasonic sensor [14], [15], laser scanner [16], [17], and RFID [20].

SLAM algorithm can be classified into various type depends on the sensor used as its input. This is due to different SLAM algorithm will consider different assumption when interface with different kind of sensor to improve the localization and mapping accuracy [18]. For example, Hector SLAM is part of the laser-based SLAM that utilizes input from a laser scanner.

Hector SLAM works by combining both 2D SLAM system based on continuous scan matching and 3D navigation technique with the aid of a inertial sensing system. Besides that, unlike other SLAM approaches such as Gmapping, Hector SLAM is non-odometry dependent. Hector SLAM algorithm is based on occupancy grid maps [17]. This means the algorithms is processing the environment in the form of cells and each cell will carry specific information (i.e unknown, occupied or free) [18].

### 2.2. Gas Distribution Mapping (GDM)

Gas distribution mapping (GDM) is the task to estimate and visualize the spatial gases distribution with the assistant of a mobile robot. The first study on GDM is conducted by Hayes, Martinoli, and Goodman in the year 2002 where a group of autonomous mobile robot is being used to investigate and localize gas source [19]. However, it is believed that this approach is not suitable for real-world implementation due to its high cost [20]. Besides that, when a group of autonomous mobile robot is moving around, their movement will disturb the air flow in the environment. Hence, worsen the difficulty to localize gas source accurately.

In the year 2003, a method known as Kernel DM has been introduced by A. Lilienthal and Duckett. This proposed method "views" the surrounding as a grid cell and each of the cell consists of the estimated gas distribution mean value. By referring to a single cell, Kernel DM estimates the value of the neighbouring cells based on their distance with the single cell. This means that each of the cells at any time will have the predictive mean for all the measurement. This method has eased the performance of the robot because the robot does not need to move all the place to cover all the region [21]. After six years, the similar authors have proposed an improved version of Kernel DM known as Kernel DM+V which include the computation of predictive variance [22]. With the computation of predictive variance, the accuracy of gas source location prediction improved, compared to solely depends on predictive mean [22].

After Kernel DM+V has been introduced, several researchers have modified and improved the algorithm of Kernel DM+V to suit for their application. For example, [23] has modified the existing Kernel DM+V by replacing the Gaussian kernel function with Epanechnikov kernel. With the implementation of the Epanechnikov kernel, the numbers of cells involved in each gas source prediction will decrease and hence, the scope of prediction will be limited, and accuracy can be increased with less assumption. Besides that, similar author has proposed a new approach, DM+V/T/H that includes both temperature and humidity of the environment with the modified version of DM+V [24]. Despite all the versions proposed [11], [19], [21], [22], there is no implementation made available in ROS and made open source.

### 2.3. SLAM-GDM Implementation

With the implementation of SLAM-GDM approach, the mobile robot will be capable to perform GDM without prior knowledge about its environment and its position. This approach will enable the mobile robot to perform SLAM and GDM simultaneously hence, output a single grid map based two-dimensional representation consists of both obstacles in the environment and spatial distribution of gas concentration. To the author's knowledge, there are only two works that have implemented SLAM-GDM approach: [11], [25]. A Rao-Blackwellised particle filter approach has been used by [25] to combine both SLAM and GDM while [11] performs the SLAM-GDM approach by replacing the unoccupied cells SLAM's occupancy grid map with the gas distribution.

## 3. Methodologies

### 3.1. System Structure

There is a total of two systems required in this approach: the base station system and mobile robot system. An Asus A555L Series laptop with 8GB of RAM and Raspberry Pi 3 Model B (raspi) have been used as the base station and mobile robot, respectively. Both systems are installed with Linux based operating system. Ubuntu 18.04 with ROS Melodic has been installed for base station while Ubuntu Mate with ROS Kinetic for mobile robot.

There are two main components on top of the mobile robot: raspi and Arduino Nano. Raspi is connected to three components: 1) camera for teleoperation, 2) RPLIDAR for mobile robot localization and mapping and 3) Arduino Nano. The Arduino Nano is used to control the motors and interface with the gas sensor module. Both motors controlling task and gas sensor module interfacing task cannot be accomplished by raspi. This is due to raspi consists of 3.3V logic signal voltage digital input and output pins only. It cannot interface with the analogue signal as well as sensors and actuator that require 5V logic signal voltage. Additional voltage level shifter and Analogue-to-Digital Converter (ADC) are needed for raspi to be able to accomplish the task. However, to reduce the circuitry complexity in this project, an Arduino Nano has been used to interface with both gas sensor module and motor driver. Both RPLIDAR and gas sensor module data will then be transmitted to the base station for SLAM and Kernel DM computation. Lastly, data fusion will be conducted to integrate SLAM and GDM. Figure 1 shows the system architecture implemented in this project.

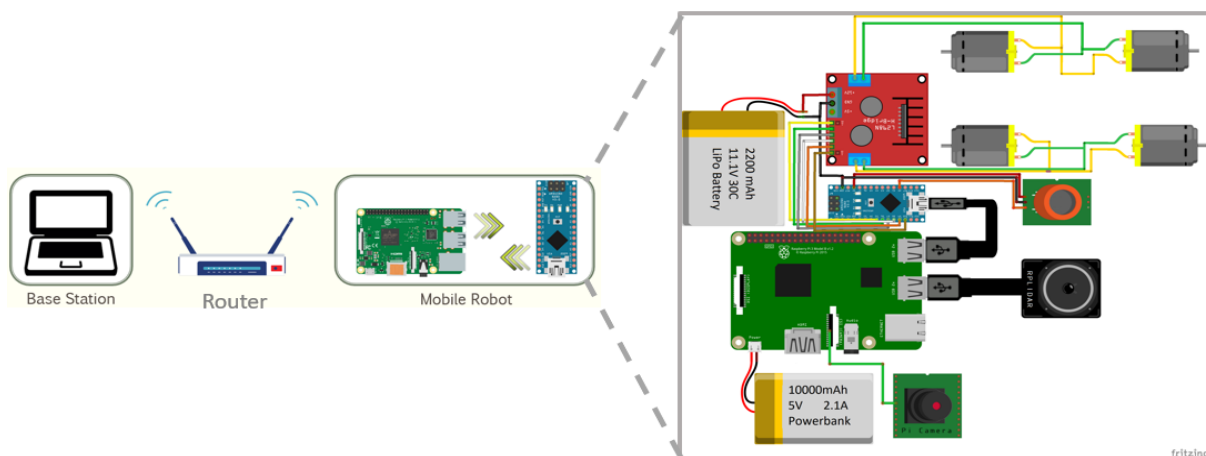

Figure 1: System Architecture

There are three configurations that must be carried out when more than one ROS machine is involved. First, all ROS machines used in this project must share a similar network. Second, only one ROSmaster is allowed in one ROS operation, where the ROSmaster generally responsible for locating and establishing peer-to-peer communication between ROS nodes. Lastly, Network Time Protocol

(NTP) such as *chrony* and *ntpdate* must be used to synchronize system time of all ROS machines involved in the project.

### 3.2. Base Station Configuration

Base station serves as the ROSmaster of this project and it is used to perform numeral tasks such as control the movement of the mobile robot as well as processing and visualizing all the data received from the mobile robot. Three main features of base station will be discussed in this section.

**3.2.1. Simultaneous Localization and Mapping (SLAM).** SLAM is often used in mobile robot application to construct the landscape of an unknown environment and predict the location of the mobile robot on the map. Hector SLAM, an Open-Source non-odometry dependent SLAM approach has been implemented in this project. The advantages of Hector SLAM implementation including SLAM performance will not be affected due to the surface condition the mobile robot moves on and its performance will also not be affected by wheel slip [23]. Hector SLAM module in ROS works by having one of its nodes known as `hector_mapping` to subscribe to the laser scan topic for calculating and publish two important topics SLAM map topic and robot pose topic. SLAM map topic is a type of OccupancyGrid type topic. It is used to describe the condition of a cell as free, occupied or unknown. Meanwhile, robot pose topic is a PoseStamped type topic that provides an estimated position of the mobile robot. Both topics will then be used by RVIZ to construct a map and locate the location of the mobile robot within the map respectively.

**3.2.2. Kernel DM.** Kernel DM algorithm has been used in this project to achieve the goal of generating GDM. Kernel DM is a statistical approached algorithm for gas distribution modelling proposed by [22]. Kernel DM algorithm implementation involves four equations:

$$\mathcal{W}^{(k)} = \sum_{i=1}^n \mathcal{N}(|x_i - x^{(k)}|, \sigma) \quad (1)$$

$$\mathcal{R}^{(k)} = \sum_{i=1}^n \mathcal{N}(|x_i - x^{(k)}|, \sigma) \cdot r_i \quad (2)$$

$$a^{(k)} = 1 - e^{-\frac{(\mathcal{W}^{(k)})^2}{\sigma \mathcal{W}^2}} \quad (3)$$

$$r^{(k)} = a^{(k)} \frac{\mathcal{R}^{(k)}}{\mathcal{W}^{(k)}} + \{1 - a^{(k)}\} r_0 \quad (4)$$

Uni-variate Gaussian weighting function  $\mathcal{N}$  has been used in Kernel DM to determine how significant location  $x_i$ 's sensor reading  $r_i$  toward cell  $\kappa$  when constructing gas distribution mapping.  $\mathcal{W}^{(k)}$  and  $\mathcal{R}^{(k)}$  are known as cell confidence summation and cell weighted reading summation, respectively.  $x^{(k)}$  stands for cell  $\kappa$ 's centre while the kernel width of the algorithm is represented by  $\sigma$ . Cell  $\kappa$  that is located nearer to  $x^{(k)}$  tends to have higher value for  $\mathcal{W}^{(k)}$  and vice versa. The result of  $\mathcal{W}^{(k)}$  is then normalized by using  $a^{(k)}$ . Hence, all the reading normalized by  $a^{(k)}$  will be scaled into the range of 0 to 1. This result of  $a^{(k)}$  will then be utilized to calculate the mean concentration estimate  $r^{(k)}$  where  $r_0$  can be defined as the overall mean for all the gas concentration reading. Once the mean concentration estimate is obtained for all the cells, a mean map will be obtained.

This has shown that to implement Kernel DM algorithm, several parameters such as robot position and gas sensor reading, must be provided. This can be done by having the Kernel DM node to subscribe to both sensors reading topic and robot pose topics. By computing Kernel DM algorithm, an array of cells position with respective gas concentration level will be obtained.

### 3.3. SLAM and GDM Integration

A SLAM-GDM map can be defined as a representation for the spatial distribution of gas concentration level by combining both maps of Hector SLAM and Kernel DM. Therefore, it is very crucial to ensure both Hector SLAM and Kernel DM obtain sufficient information for their computation. Figure 2 shows the software architecture of the ROS based environment to generate SLAM-GDM map.

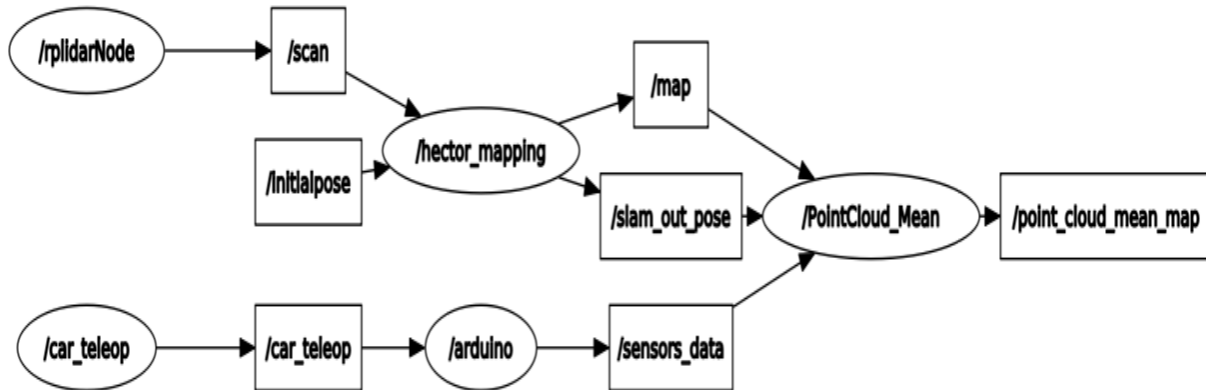

Figure 2: Software Architecture of ROS based System

A ROS node known as rplidarNode has been deployed on the mobile robot's raspi. By having RPLIDAR's data as its input, it will publish all the received data to a topic known as /scan. A ROS node of Hector SLAM, hector\_mapping will then subscribe to the /scan topic and /initialpose topic (consists of the initial position of the mobile robot) to compute and publish SLAM map under /map topic. Hector\_mapping will also publish a /slam\_out\_pose topic that provides information about the mobile robot's position and it will be updated at the scan rate of the laser scanner used.

To control the movement of the mobile robot from the base station, a ROS node called car\_teleop has been deployed at the base station. It will publish the movement command to /car\_teleop topic subscribed by the Arduino (ROS node of Arduino Nano) and hence, the performance of the motors can be controlled from the base station. Meanwhile, Arduino Nano will also publish a custom message under the /sensors\_data topic. Since it is a custom message, all the ROS machines involved must have the custom message created to be able to recognize and extract data from it.

By having /map, /slam\_out\_pose and /sensors\_data topics published, PointCloud\_Mean ROS node that responsible to generate SLAM-GDM representation will begin its computation. There are two possible approaches can be implemented to achieve the objective of SLAM and GDM integration: (1) overlap the GDM on top of the global map generated by Hector SLAM; (2) reconstruct and merge the global map with GDM to form a single global GDM map. The second approach will be used for this project as it eases the process of data analysis since all the data is store within the same array. To realize this approach, two steps are required: map type conversion and data fusion.

**3.3.1. Map Type Conversion.** The first step needs to be done to achieve this objective is to convert the global map generated by the Hector SLAM in the type of Occupancy Grid map to Point Cloud. This is due to the Occupancy Grid map consists of three states (free, occupied and unknown) only and it is not suitable to be used to store any value of Kernel DM. Besides that, due to its nature to have three states only, it cannot display other colours besides white (free cell), grey (unknown cell) and black (occupied cell). Therefore, type conversion to Point Cloud type is necessary for the representation able to provide useful information.

**3.3.2. Data fusion.** With both outputs of Kernel DM algorithm (cells coordinate with its gas concentration level) and Point Cloud SLAM map are ready, both data can now be fused together to generate a SLAM-GDM map based on the approach proposed by [11]. The process begins by storing all the Point Cloud SLAM map data in an array, without publishing it. Next, the Point Cloud data



generated from Kernel DM algorithm should be inserted into a similar array to replace the SLAM cells that are free only. This will retain the structure of SLAM map while introducing gas concentration level information onto free cell to achieve the objective of constructing SLAM-GDM representation.

Different colour should be distributed to the Point Cloud geometry to indicate different cell conditions. This will help the user performs a better analysis besides illustrating the relationship between each of the cell. The colour assignation for each cell condition is as follow:

$$[r, g, b] = \begin{cases} [0, 0, 0], & \text{Occupied,} \\ [220, 220, 220], & \text{Unknown,} \\ [255 - H^{(k)}, 255 - L^{(k)}, 0], & \text{Gas Concentration Level,} \end{cases} \quad (5)$$

$$H^{(k)} = \begin{cases} ((r^{(k)} - r_{ave})(r_{max} - r_{ave})^{-1}) * 255, & r^{(k)} > r_{ave}, \\ 0, & \text{otherwise,} \end{cases} \quad (6)$$

$$L^{(k)} = \begin{cases} ((r_{ave} - r^{(k)})(r_{ave} - r_{min})^{-1}) * 255, & r^{(k)} \leq r_{ave}, \\ 0, & \text{otherwise,} \end{cases} \quad (7)$$

For occupied cells and unknown cells, the colour assigned is black and grey respectively. Colour for free cell will depends on its gas concentration level reading. Equation (6) and Equation (7) show the effect of gas concentration reading on the colour of free cell. The lower the gas concentration level reading, the greener the free cell (Equation 7) while the higher the gas concentration level reading, the redness of the free cell increase (Equation 6). The average reading for gas concentration level has been used as the even point for this bipolar scaling approach. When the reading of the free cell is near to the average value of gas concentration level, yellow colour will dominate.

#### 4. Experimental Result

The first part of this section will be focusing on the performance analysis of online SLAM-GDM algorithm by using Rosbag data collected in CEASTech as presented in [11]. Each of the rosbags used has a different gas source location. Therefore, the predicted gas source location is expected not to be similar. Table 1 illustrates the accuracy of the SLAM-GDM by calculating its error in prediction on ethanol gas source location. The purple filled circle and blue filled circle indicate the actual location for ethanol gas source and predicted gas source location respectively. In this work, an average accuracy of below 1m is preferred. Based on the results, the average accuracy of SLAM-GDM representation on predicting gas source location is approximately 0.71m. Hence, the proposed Kernel DM based GDM algorithm is deemed suitable for gas source localization application.

Table 1: Accuracy of SLAM-GDM Representation on Gas Source Location Prediction

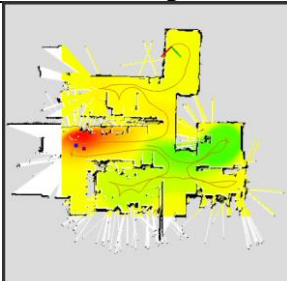
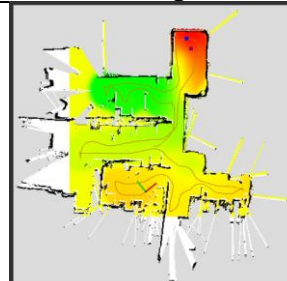
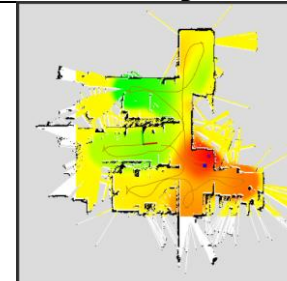
	Rosbag 1	Rosbag 2	Rosbag 3
SLAM-GDM Map			
Error (m)	0.61	0.79	0.74

The next experiment conducted is to evaluate the consistency of the SLAM-GDM map in predicting ethanol gas source solution. The experiment is conducted in UniMAP Solution of Universiti

Malaysia Perlis (UniMAP) by utilizing a mobile robot, where the ethanol gas source is fixed at a location throughout the three experimental trials. Table 2 shows the consistency of SLAM-GDM representation to predict a fixed gas source location. From the results of the experiment, the average error in predicting the gas source location is approximately 0.32m. There are two factors detected that have affected the result of this experiment. First, the area of gas dispersing increase with time. This led to significant prediction difference between Trial 1 and Trial 2. Second, a trailing gas concentration level is visualized after the mobile robot pass by the gas source location. This is caused by the memory effect of TGS2600 gas sensor and the high mobile robot movement speed. Memory effect occurs due to the gas sensor used in this project has a long recovery time. It takes several seconds for the gas sensor to readjust its reading back to surrounding gas concentration level. By having a gas sensor module with shorter recovery time and a robot with slower movement, the performance of SLAM-GDM representation can be improved.

Table 2: Consistency of SLAM-GDM Representation on Gas Source Location Prediction

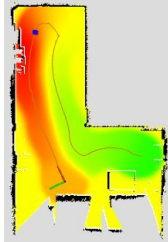
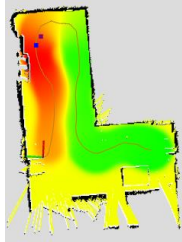
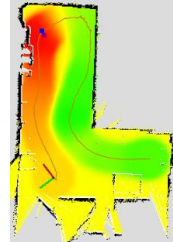
	Trial 1	Trial 2	Trial 3
SLAM-GDM Map			
Error (m)	0.10	0.59	0.28

## 5. Conclusion

Involvement of the mobile robot in the inspection of gas leakage incident surely will become very beneficial for human. This allows the number of humans needed to be exposed to the harmful environment will be reduced and hence, the number of casualties can be kept minimal. With the implementation of SLAM-GDM algorithm on ROS, the mobile robot will also provide better gas source location prediction in an unknown environment.

The conducted experiences have shown that the average accuracy and consistency of SLAM-GDM map performance on predict gas source location are 0.71m and 0.32m respectively which fulfil author's requirement of below 1m. Therefore, the performance of SLAM-GDM representation is reliable. The performance can be further improved by increasing number of sensors implemented such as wind sensor to access the magnitude and direction of air flow surrounding the mobile robot or introducing variance into the Kernel DM algorithm.

## 6. Acknowledgement

The author would like to acknowledge the support from the Fundamental Research Grant Scheme (FRGS) under a grant number of FRGS/1/2018/TK04/UNIMAP/02/15 from the Ministry of Education Malaysia.

## References

- [1] Asian Oil & Gas staff 2014 Aasta Hansteen Field Shut after Gas Leak *Asian Oil & Gas* Aasta Hansteen Field.
- [2] Bernama 2018 Ammonia leak at ice factory: Two dead, 18 hurt - Nation | The Star Online *The Star Online*. [Online]. Available: <https://www.thestar.com.my/news/nation/2018/08/13/ammonia-leak-at-ice-factory-two-dead-18-hurt/>. [Accessed: 11-Dec-2018].
- [3] R. Mani 2019 Allahabad: Gas leakage in IFFCO plant, four labourers taken ill *Times of India* Allahabad.



- [4] United News of India 2019 Ammonia gas leakage: 15 fell ill in Mathura *United News of India* Mathura.
- [5] M. Shneier Literature Review of Mobile Robots for Manufacturing Literature Review of Mobile Robots for Manufacturing.
- [6] B. S. Barker, G. Nugent, N. Grandgenett, and V. I. Adamchuk 2012 Robots in K-12 Education - A New Technology for Learning *J. Educ. Technol. Soc.*, vol. 19, no. 2, pp. 148–163.
- [7] A. Tapus, C. Tapus, and M. Mataric 2006 User-robot personality matching and assistive robot behavior adaptation for *J. Robot. Soc.* ..., pp. 169–183.
- [8] R. A. Beasley 2012 Medical Robots: Current Systems and Research Directions *J. Robot.*, vol. 2012, pp. 1–14.
- [9] H. Şahin and L. GuÜvenç 2007 Household Robotics Autonomous Devices for Vacuuming and Lawn Mowing *IEEE Control Syst.*, vol. 27, no. 2, pp. 20–96.
- [10] Zakri Abdul Hamid 2017 The robot revolution | New Straits Times | Malaysia General Business Sports and Lifestyle News *New Straits Times*. [Online]. Available: <https://www.nst.com.my/news/2017/04/228029/robot-revolution>. [Accessed: 20-Apr-2019].
- [11] K. Kamarudin *et al.* 2018 Integrating SLAM and gas distribution mapping (SLAM-GDM) for real-time gas source localization *Adv. Robot.*, vol. 32, no. 17, pp. 903–917.
- [12] Y. Wu, F. Tang, and H. Li 2018 Image Based Camera Localization : an Overview Invited Paper by Visual Computing for Industry , Biomedicine and Art , 2018 *Invit. Rev.*, pp. 1–21.
- [13] A. J. Davison, I. D. Reid, N. D. Molton, and O. Stasse 2007 MonoSLAM: Real-time single camera SLAM *IEEE Trans. Pattern Anal. Mach. Intell.*, vol. 29, no. 6, pp. 1052–1067.
- [14] P. Yang 2012 Efficient particle filter algorithm for ultrasonic sensor-based 2D range-only simultaneous localisation and mapping application *IET Wirel. Sens. Syst.*, vol. 2, no. 4, pp. 394–401.
- [15] L. D’Alfonso, A. Grano, P. Muraca, and P. Pugliese 2013 A polynomial based SLAM algorithm for mobile robots using ultrasonic sensors - Experimental results *2013 16th Int. Conf. Adv. Robot. ICAR 2013*, pp. 1–6.
- [16] K. Kamarudin, S. M. Mamduh, A. S. A. Yeon, R. Visvanathan, A. Y. M. Shakaff, and A. Zakaria 2015 Improving Performance of 2D SLAM Methods by Complementing Kinect with Laser Scanner pp. 278–283.
- [17] J. M. Santos, D. Portugal, and R. P. Rocha 2013 An evaluation of 2D SLAM techniques available in Robot Operating System *2013 IEEE Int. Symp. Safety, Secur. Rescue Robot. SSR 2013*.
- [18] M. Rojas-fern, M. Dante, M. Matuz-cruz, and L. Diana 2018 PERFORMANCE COMPARISON OF 2D SLAM TECHNIQUES AVAILABLE IN ROS USING A p. 5386.
- [19] A. T. Hayes, A. Martinoli, and R. M. Goodman 2002 Distributed odor source localization *IEEE Sens. J.*, vol. 2, no. 3, pp. 260–271.
- [20] X. Liu *et al.* 2012 A survey on gas sensing technology *Sensors (Switzerland)*, vol. 12, no. 7, pp. 9635–9665.
- [21] A. Lilienthal 2003 Creating Gas Concentration Gridmaps with a Mobile Robot *Nevada Octoer*.
- [22] A. J. Lilienthal, M. Reggente, M. Trinca, J. L. Blanco, and J. Gonzalez 2009 A statistical approach to gas distribution modelling with mobile robots - The Kernel DM+V algorithm *2009 IEEE/RSJ Int. Conf. Intell. Robot. Syst. IROS 2009*, pp. 570–576.
- [23] K. Bin Kamarudin 2016 An Improved Mobile Robot Based Gas Source Localization with Temperature and Humidity Compensation via SLAM and Gas Distribution Mapping no. 1140610652.
- [24] H. W. Liu, S. Ma, W. Li, H. G. Gu, Y. G. Lin, and X. J. Sun 2011 A review on the development of tidal current energy in China *Renewable and Sustainable Energy Reviews*.
- [25] A. J. Lilienthal, A. Loutfi, J. Blanco, C. Galindo, and J. Gonzalez-jimenez 2007 A Rao-Blackwellisation Approach to GDM-SLAM – Integrating SLAM and Gas Distribution Mapping (GDM) *Eur. Conf. Mob. Robot.*, no. September, pp. 126–131.